



ELSEVIER

Contents lists available at ScienceDirect

## Journal of Theoretical Biology

journal homepage: [www.elsevier.com/locate/jtbi](http://www.elsevier.com/locate/jtbi)

# Construction of a mathematical model for tuberculosis transmission in highly endemic regions of the Asia-Pacific

James M. Trauer<sup>a,b,c,\*</sup>, Justin T. Denholm<sup>b,d</sup>, Emma S. McBryde<sup>a,b,c</sup><sup>a</sup> Burnet Institute, 89 Commercial Road, Melbourne 3004, Australia<sup>b</sup> Victorian Infectious Diseases Service at the Peter Doherty Institute for Infection and Immunity, Victoria 3010, Australia<sup>c</sup> Department of Medicine (Royal Melbourne Hospital/Western Hospital), University of Melbourne, Victoria 3010, Australia<sup>d</sup> Department of Microbiology and Immunology, University of Melbourne, Victoria 3010, Australia

## H I G H L I G H T S

- We present a model for simulation of programmatic responses to tuberculosis in highly endemic countries of the Asia-Pacific.
- The model presented cannot be calibrated to estimated incidence rates without allowing for reinfection during latency.
- Even in the presence of a moderate fitness cost, MDR-TB dominates at equilibrium.
- Improved treatment of drug-susceptible TB does not result in decreased rates of MDR-TB through prevention of *de novo* resistance.
- Community transmission to MDR-TB incidence contributes markedly more to MDR-TB burden than resistance amplification under our model structure.

## A R T I C L E I N F O

## Article history:

Received 19 December 2013

Received in revised form

8 April 2014

Accepted 15 May 2014

Available online 27 May 2014

## Keywords:

Models—Theoretical

Tuberculosis—Multidrug Resistant

Disease Transmission—Infectious

Latent tuberculosis

BCG vaccine

## A B S T R A C T

We present a mathematical model to simulate tuberculosis (TB) transmission in highly endemic regions of the Asia-Pacific, where epidemiology does not appear to be primarily driven by HIV-coinfection. The ten-compartment deterministic model captures many of the observed phenomena important to disease dynamics, including partial and temporary vaccine efficacy, declining risk of active disease following infection, the possibility of reinfection both during the infection latent period and after treatment, multidrug resistant TB (MDR-TB) and *de novo* resistance during treatment. We found that the model could not be calibrated to the estimated incidence rate without allowing for reinfection during latency, and that even in the presence of a moderate fitness cost and a lower value of  $R_0$ , MDR-TB becomes the dominant strain at equilibrium. Of the modifiable programmatic parameters, the rate of detection and treatment commencement was the most important determinant of disease rates with each respective strain, while vaccination rates were less important. Improved treatment of drug-susceptible TB did not result in decreased rates of MDR-TB through prevention of *de novo* resistance, but rather resulted in a modest increase in MDR-TB through strain replacement. This was due to the considerably greater relative contribution of community transmission to MDR-TB incidence, by comparison to *de novo* amplification of resistance in previously susceptible strains.

© 2014 The Authors. Published by Elsevier Ltd. This is an open access article under the CC BY-NC-SA license (<http://creativecommons.org/licenses/by-nc-sa/3.0/>).

## 1. Introduction

Although progress is being made in control of tuberculosis (TB), the global burden of disease remains enormous, several high burden countries are not on track to achieve Millennium Development Goal targets and multidrug-resistant TB (MDR-TB) has emerged as a major threat to control measures (World Health

Organization, 2013c). In the Asia-Pacific region, here defined as countries within the World Health Organisation South East Asia Region (SEARO) and Western Pacific Region (WPRO) jurisdictions, seven countries have an incidence of greater than 300 per 100,000 per year (World Health Organization, 2013c).

MDR-TB is defined as TB resistant to both of the two most effective first line anti-tuberculous agents; rifampicin and isoniazid. Such strains require treatment that is substantially more difficult, in relation to patient tolerance, duration of therapy and expense. In the Asia-Pacific region, MDR-TB is a serious problem, representing a significant proportion of incident cases, despite probable under-reporting (Gilpin et al., 2008). By contrast, although the burden of HIV in some such countries is also significant, the large majority of

\* Corresponding author at: Burnet Institute, 89 Commercial Road, Melbourne 3004, Australia.

E-mail addresses: [jtrauer@burnet.edu.au](mailto:jtrauer@burnet.edu.au) (J.M. Trauer), [justin.denholm@mh.org.au](mailto:justin.denholm@mh.org.au) (J.T. Denholm), [emma.mcbryde@mh.org.au](mailto:emma.mcbryde@mh.org.au) (E.S. McBryde).

TB cases occurs in HIV-negative persons. Unlike sub-Saharan Africa, the prevalence of HIV in adults aged 15–49 is generally less than 1% and so does not appear to be driving the regional TB epidemic (World Health Organization, 2013a).

Prolonged latency between infection and subsequent disease is characteristic of TB and has important implications for epidemiology (Blower et al., 1995). Therefore, from the earliest mathematical models of TB transmission, latent compartments have been incorporated (Waalder et al., 1962). Such studies typically model the incidence of active cases as proportional to the number of persons latently infected, and represent the force of infection as a function of the number of persons with active infection (ReVelle et al., 1967), usually assuming frequency-dependent transmission (Feng et al., 2001).

Most previously developed models aim to answer specific questions about the likely impact of individual interventions on the burden of TB in a hypothetical population. While models have been developed to estimate the global impact of a bundled intervention such as DOTS (Dye et al., 1998), the practical impact of implementation of multifactorial programmatic strategies at a local or regional level is less frequently modelled. In this study, we aimed to create a model structure that would be applicable to countries highly endemic for TB and MDR-TB, but with low HIV prevalence, and to describe its basic behaviour. We developed a compartmental deterministic model with frequency-dependent transmission that aims to incorporate the most current understanding of TB epidemiology to use as a realistic base for modelling of programmatic interventions in highly endemic countries of our region. The model allows for the incorporation of multiple aspects of a programmatic response to TB, in order to compare a number of scenarios simulating such responses.

The paper is organised as follows. Section 2 describes each aspect of the model construction in detail, while Section 3 describes the behaviour of the model and presents a sensitivity analysis for modifiable parameters.

## 2. Model construction

### 2.1. Immunisation

BCG is known to provide partial protection against infection with TB (Colditz et al., 1994). Past models for TB transmission in developed countries have represented this partial immunity as a compartment of fully immune individuals, with the flow entering the compartment proportional to the product of vaccine efficacy and vaccine coverage (Vynnycky and Fine, 1997). BCG may have particular efficacy in preventing disease in the years following vaccination (Medical Research Council, 1972), although this immunity may be overwhelmed by repeated exposure in a highly endemic setting. Therefore, representing vaccination as complete and permanent immunity for a proportion of the population may not be applicable to highly endemic developing countries. We represent BCG effect as a proportional reduction in the force of infection for those vaccinated, and as providing no further protective effect after infection has occurred. As BCG is administered as a neonatal vaccine, birth cohorts are split between vaccinated and fully susceptible compartments.

### 2.2. Latency

Markedly different rates of progression to active infection are observed in the years following infection with TB, by comparison to subsequent years remote from infection. Over the first 23 months following infection by a smear-positive index case confirmed by positive interferon-gamma release assay, 12.9% of patients progressed

to active disease (Diel et al., 2011). By contrast, the rate at which active disease develops once this high risk period has ended is generally modelled at a much lower rate, e.g. 5–10% over 20 years (Blower et al., 1995).

To represent this clinical observation, past models have included both fast and slow pathways from susceptible to actively infected, with a proportion of exposed susceptibles progressing immediately to active infection (Basu and Galvani, 2008; Blower et al., 1995; Rodrigues et al., 2007). This approach allows slight modification of the standard exponential function governing sojourn time in the exposed, non-infectious compartment. Other models have utilised alternative distributions of the latent period, including a stepwise reduction in the rate of progression occurring five years after exposure (Vynnycky and Fine, 1997), and an arbitrary distribution of the latent period, which was demonstrated to retain important model properties (Feng et al., 2001). However, dual latent compartments linked by constant flow rates are increasingly utilised to represent the high and low risk periods following infection. These compartments may either be included as a sequential progression from early to late latent (Aparicio et al., 2002; Dowdy et al., 2013; Wu et al., 2010; Ziv et al., 2001) or allow for bypass of the early latent compartment with immediate entry into the late latent compartment after infection (Abu-Raddad et al., 2009; Dye and Williams, 2008).

We included two sequential latent compartments in our model to simulate the increased risk of progression to active disease in the years immediately following initial infection.

### 2.3. Diagnosis and commencement on treatment

The process of actively infected patients commencing on effective treatment can be divided into multiple compartments, and previous models have separated patient-related pre-health system delays from health system delays (Dye, 2012), or have distinguished pre-diagnosis delays from delays to treatment after diagnosis (Hickson et al., 2012). However, provided that ‘patients yet to present to hospital’, ‘patients yet to be diagnosed after presentation’, and ‘patients diagnosed but yet to start treatment’ are all considered to have the same mortality and infectiousness, representing all delays to treatment commencement within one model pathway is the most parsimonious approach. Pre-health system delays and post-diagnosis, pre-treatment delays can still be quantified by dividing the proportion who ever receive treatment by the typical period of delay to treatment, while missed diagnosis leading to undertreatment could be incorporated by multiplying the rate of movement from infectious to susceptible by the sensitivity of the test used. Therefore, consistent with the approach of several previous models (Abu-Raddad et al., 2009; Blower et al., 1996; Dowdy et al., 2013; Dye and Williams, 2008), we incorporated all stages from onset of symptoms to commencement on treatment within the same model compartment.

### 2.4. Recovery

Most previous models present a separate compartment for previously treated and spontaneously recovered individuals from the compartments representing individuals who are fully susceptible or previously vaccinated, allowing these individuals to be conferred a different rate of infection. The different approaches to quantifying this modified rate of infection include; assuming no further risk of infection after recovery (Blower et al., 1996; Dye and Williams, 2008), assuming all recurrent cases are due to relapse, (Blower et al., 1995) assuming the same risk modification as for latent infection (Dowdy et al., 2013), assuming the same rate of reinfection as for susceptible individuals (Castillo-Chavez and Feng, 1997), and allowing for both reinfection and relapse after

treatment (Wu et al., 2010). Therefore, consensus has not been reached as to whether recovered individuals should be conferred no risk, reduced risk, equivalent risk or higher risk than fully susceptible individuals.

Exogenous reinfection following treatment has long been thought to occur in some previously treated immunocompetent patients (Raleigh and Wichelhausen, 1973) and has more recently been confirmed with molecular epidemiological techniques (Bandera et al., 2001). However, the rate with which this occurs, relative to fully susceptible individuals is uncertain. A review of recurrent TB episodes found that the proportion of recurrent cases that were due to subsequent infection— as opposed to relapse with the same strain—varied widely from 0 to 100% (Lambert et al., 2003). However, the review stressed that relapse and reinfection should be considered separate processes, which is likely to be responsible for the degree of variability in results.

Individual studies from highly endemic regions have found rates of reinfection after treatment to be variable, which likely reflects the degree of continuing exposure after treatment (Das et al., 1995; Sahadevan et al., 1995; Sonnenberg et al., 2001; van Rie et al., 1999; Verver et al., 2005). Our model represents this continued exposure by allowing previously treated individuals to return to a partially susceptible state after completion of effective treatment. As none of the above studies compare risk of infection or disease between cohorts of fully susceptible and previously infected patients, the absolute rate of reinfection after treatment is impossible to directly quantify. Modelling studies based on published epidemiological datasets suggest that although recovered individuals are at increased risk for subsequent disease, this effect is most likely mediated by the population effect of high-risk individuals developing disease more frequently, rather than infection itself leading to increased susceptibility (Gomes et al., 2012). Therefore, as both BCG vaccination and past TB disease represent exposure to a TB-family organism, we consider it biologically plausible for both situations to lead to partial immunity, and so return fully treated individuals to the partially immune compartment ( $S_B$ ).

Based on the above discussion, we modelled spontaneously recovering individuals as return to late latency ( $L_B$  or  $L_{Bm}$ ) with the equivalent strain. This assumes that those persons remaining within the active infection compartments ( $I$  or  $I_m$ ) for three years (the effective sojourn time untreated) remain infected and at risk of future disease.

### 2.5. Reinfection during latency

As immunity following recovery is incomplete, immunity during latency may well be similar, and repeated exposure to infectious TB during latency (i.e. reinfection or superinfection) is likely to occur frequently in highly endemic populations. Some recent TB models incorporate reinfection, either allowing replacement with the infecting strain (Dowdy et al., 2008) or the coexistence of multiple strains during latency (Colijn et al., 2009). Approaches to modelling the rate of reinfection differ, with some models applying the same rate of infection as for those never previously exposed (Vynnycky and Fine, 1997; Wu et al., 2010), while others apply a lower rate (Abu-Raddad et al., 2009; Feng et al., 2000). Such models have been used to demonstrate that reinfection is likely to have waned in importance during the latter part of the 20th century as TB incidence decreased, implying that reinfection is more important in highly endemic settings.

Applying a lower risk of disease following re-exposure is consistent with animal models demonstrating partial protection from subsequent reactivation following a first infection (Ziegler et al., 1985). Modelling based on epidemiological data from the Netherlands indicates that the risk of developing active TB after reinfection is around 2% per year over the five years following reinfection, by comparison to 5% per year for primary infection

(Sutherland et al., 1982). This 0.38 relative risk of reinfection following treatment of past infection observed in the Netherlands is within the confidence intervals of the estimated efficacy of BCG vaccination (Colditz et al., 1994). Moreover, a similar risk modification following past infection as after BCG vaccination is biologically plausible, as both situations represent past exposure to a TB-family organism. Therefore, in the absence of evidence for significantly difference risks for these patient groups, we applied the same risk modification to latently infected individuals as for the vaccinated and recovered groups.

### 2.6. Drug-resistance

Previous models have considered multiple strains of TB differing by their drug-resistance profile, with the proportion of the population infected with each strain determining the respective force of infection. Earlier models did not include effective treatment of drug-resistant strains, either assuming the resistant strain to be untreatable (Castillo-Chavez and Feng, 1997; Feng et al., 2002), or applying a relative reduction in efficacy of standard short-course treatment to the more resistant strain (Blower et al., 1996). More recent studies have modelled the emergence of progressively drug-resistant TB (Cohen et al., 2009), and have further considered the impact of HIV on this process in a setting highly endemic for both infections (Sergeev et al., 2012). Despite this the modelling literature remains sparse in relation to programmatic responses to this important problem.

In developing countries it remains impractical to introduce programmatic responses to extensively drug-resistant TB before the response to MDR-TB has been considered. By contrast, the marked differences in treatment duration and expense associated with MDR-TB regimens make consideration of the response to this strain essential. Therefore, to best consider the programmatic implications of drug-resistant TB, we present a two strain model.

### 2.7. Default and resistance amplification

By contrast to the situation with previously fully treated patients, most cases of recurrence after default are due to relapse with the same strain (Verver et al., 2005). Therefore, our model structure returns defaulting patients to the infectious compartment of the same strain susceptibility, unless amplification occurs.

While our model allows for circulation of MDR-TB strains, we also considered the emergence of new drug-resistance in a strain of TB previously known to be drug-susceptible in response to inappropriate treatment.

Past studies have modelled amplification occurring from the treatment compartment (Blower and Chou, 2004), and most often consider the rate of amplification to be proportional the rate of treatment of drug-susceptible strains (Blower et al., 1996; Castillo-Chavez and Feng, 1997; Feng et al., 2002; Rodrigues et al., 2007; Sergeev et al., 2011). It has previously been noted that when an amplification pathway is included, the drug-resistant strain no longer requires a basic reproductive number ( $R_0$ ) greater than one for equilibrium to be reached with both strains present (Castillo-Chavez and Song, 2004). Other models have allowed amplification to emerge in a constant proportion of patients who were unsuccessfully treated (Dowdy et al., 2008). As our model structure considers inadequate treatment as a pathway representing default from treatment, we considered amplification to arise at a rate constantly proportional to this rate. With an improved understanding of this process emerging through molecular techniques, this proportion can now be more clearly delineated (Cox et al., 2007; van der Werf et al., 2012).

This approach to modelling default and amplification of resistance allows consideration of the programmatic effect of modifying default rates and treatment duration on these processes.

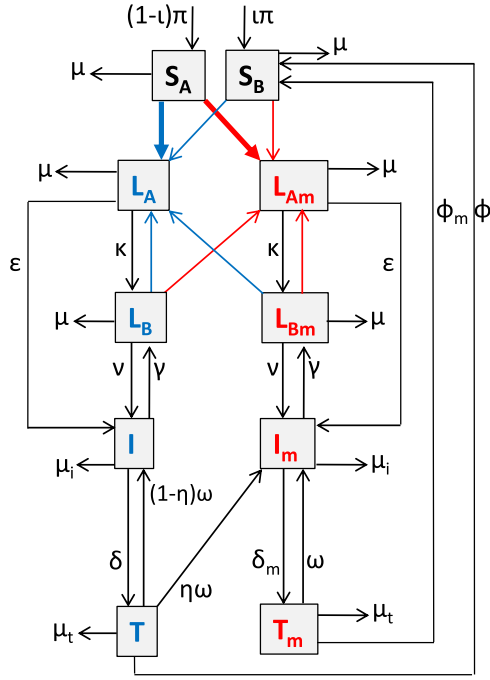

**Fig. 1.** Model structure. The compartments with  $m$  subscripts, population infected with MDR-TB; thick blue (thick solid in print version) arrow, infection with drug-susceptible TB in fully susceptible persons ( $\lambda$ ); thin blue (thick solid in print version) arrows, infection with drug-susceptible TB in partially immune persons ( $\lambda_d$ ); thick red (thick solid in print version) arrow, infection with MDR-TB in fully susceptible persons ( $\lambda_m$ ); thin red (thick solid in print version) arrow, infection with MDR-TB in partially immune persons ( $\lambda_{dm}$ ).

2.8. Model description

Fig. 1 presents the model structure. Birth ( $\pi$ ) occurs into either the  $S_A$  or  $S_B$  compartment depending upon vaccination rates ( $\iota$ ), with  $S_B$  also including previously successfully treated individuals. Following infection, individuals enter an early latent compartment ( $L_A$  or  $L_{Am}$ ) and may progress rapidly to active disease ( $\epsilon$ ) or enter the respective late latent compartment ( $L_B$  or  $L_{Bm}$ ) from which progression occurs more slowly ( $\nu$ ). Infection and reinfection with drug-susceptible TB or MDR-TB occurs for individuals who are fully susceptible, partially immune and in late latency. Persons with active disease ( $I$  and  $I_m$ ) may spontaneously cure ( $\gamma$ ), die, or be commenced on treatment ( $\delta$  and  $\delta_m$ ) and move to the respective treatment compartments ( $T$  and  $T_m$ ). Frequency dependent transmission is assumed, with the proportion of the population contained within the compartments representing both active infection ( $I$  and  $I_m$ ) and persons under treatment ( $T$  and  $T_m$ ) contributing to the force of infection with the respective strain, although the contribution of those under treatment is reduced by comparison to those with active infection. A proportion of defaulting patients ( $\eta$ ) amplify to MDR-TB and patients not dying or defaulting from treatment return to compartment  $S_B$  once treatment has been completed ( $\varphi$  and  $\varphi_m$ ). Death rates are greater for those with active infection ( $\mu_i$ ), and are modified by treatment ( $\mu_t$ ).

2.9. Equations

The system of ordinary differential equations governing the model is given by:

$$\frac{dS_A}{dt} = (1 - \iota)\pi N - (\lambda + \lambda_m + \mu)S_A$$

$$\frac{dS_B}{dt} = \iota\pi N + \varphi T + \varphi_m T_m - (\lambda_d + \lambda_{dm} + \mu)S_B$$

$$\frac{dL_A}{dt} = \lambda S_A + \lambda_d(S_B + L_B + L_{Bm}) - (\epsilon + \kappa + \mu)L_A$$

$$\frac{dL_{Am}}{dt} = \lambda_m S_A + \lambda_{dm}(S_B + L_B + L_{Bm}) - (\epsilon + \kappa + \mu)L_{Am}$$

$$\frac{dL_B}{dt} = \kappa L_A + \gamma I - (\lambda_d + \lambda_{dm} + \nu + \mu)L_B$$

$$\frac{dL_{Bm}}{dt} = \kappa L_{Am} + \gamma I_m - (\lambda_d + \lambda_{dm} + \nu + \mu)L_{Bm}$$

$$\frac{dI}{dt} = \epsilon L_A + \nu L_B + (1 - \eta)\omega T - (\gamma + \delta + \mu_i)I$$

$$\frac{dI_m}{dt} = \epsilon L_{Am} + \nu L_{Bm} + \eta\omega T + \omega T_m - (\gamma + \delta_m + \mu_i)I_m$$

$$\frac{dT}{dt} = \delta I - (\varphi + \omega + \mu_t)T$$

$$\frac{dT_m}{dt} = \delta_m I_m - (\varphi_m + \omega + \mu_t)T_m$$

where

$$\lambda = \beta\rho(I + oT)/N \quad \rightarrow$$

$$\lambda_d = \chi\beta\rho(I + oT)/N \quad \rightarrow$$

$$\lambda_m = \beta_m\rho(I_m + oT_m)/N \quad \rightarrow$$

$$\lambda_{dm} = \chi\beta_m\rho(I_m + oT_m)/N \quad \rightarrow$$

$$N = S_A + S_B + L_A + L_B + L_{Am} + L_{Bm} + I + I_m + T + T_m$$

2.10. Parameterisation

Fixed disease-specific parameters, considered to be universal to TB in any setting and unmodifiable, were estimated from a review of the best available epidemiological evidence.

Table 1 Fixed epidemiological parameter values and modifiable epidemiological parameter values during run-in periods were estimated from the mean of the published rates for the seven countries of the Asia-Pacific with incidence of greater than 300 per 100,000 per year (the Democratic Republic of Korea, Myanmar, Timor-Leste, Cambodia, Kiribati, the Marshall Islands and Papua New Guinea) (Table A2).

2.11. Run-in periods

For the sensitivity analysis and for consideration of the effects of introducing MDR-TB (Sections 3.5 and 3.6 below) an initial run-in period in the absence of MDR-TB was employed in order to reach observed estimates of disease burden. This first run-in of 100 years duration allowed total incidence to reach the target of 400 to 450 per 100,000 per year with a closed population ( $\pi$ =total deaths), with incidence calculated as the total flows entering compartment  $I$  ( $\epsilon + \kappa$ ).

Prior to sensitivity analysis (Section 3.5), a second run-in of 25 years was employed, again with a closed population, to enable the MDR-TB burden to reach observed levels. This second run-in period was necessary as our model structure confers MDR-TB a comparative advantage, such that it would dominate at equilibrium. This is due to the amplification of resistance pathway and

**Table 1**  
Model parameters.

Symbol	Parameter	Value	Source
Fixed disease parameters			
$\epsilon$	Early progression	0.129 over 23 months	Diel et al., (2011)
$\kappa$	Transition to late latency	0.821 over 23 months	
$\nu$	Reactivation	0.075 over 20 years	Blower et al. (1995)
$\gamma$	Spontaneous recovery	0.63 over 3 years	Tiemersma et al. (2011)
$\mu_i$	TB-specific death rate	0.37 over 3 years	
$\mu_t$	Treated TB-specific death rate	$0.5 \times \mu_i$	Harries et al. (2001); Moolphate et al. (2011) <sup>a</sup>
$\eta$	Amplification	0.035	Cox et al. (2007)
$o$	Treatment modification of infectiousness	0.21	Fitzwater et al. (2010)
$\chi$	Partial immunity	0.49	Colditz et al. (1994)
$\varphi$	Drug-susceptible treatment rate	2 per year	World Health Organisation (2010)
$\varphi_m$	MDR-TB treatment rate	0.5 per year	
Fixed epidemiological parameters			
$\pi$	Birth rate during run-ins	Varied to population-wide death rate <sup>b</sup>	
$\pi$	Birth rate during sensitivity analysis	0.025 per year	United Nations Department of Economic and Social Affairs/Population Division (2012)
$\mu$	TB-free mortality	0.016 per year	World Health Organisation (2013b) <sup>c</sup>
$\rho$	Infectious proportion	0.35	World Health Organisation (2013c)
Modifiable parameters (baseline values)			
$\iota$	BCG vaccination rate	0.65	World Bank (2013) <sup>d</sup>
$\delta$	Detection	0.72 per year	World Health Organisation (2013c)
$\delta_m$	MDR-TB detection	0	
$\omega$	Default rate	0.25 per year	World Health Organisation (2013c)
$\beta$	Effective contact rate	24 <sup>e</sup>	
%MDR	Proportion of incident cases MDR-TB	4–6% <sup>f</sup>	

<sup>a</sup> Estimate consistent with known significant reduction in mortality on treatment.

<sup>b</sup> Population kept closed during run-in periods, then set to observed values during sensitivity analysis.

<sup>c</sup> Reciprocal of life expectancy.

<sup>d</sup> Assuming 90% of births attended by skilled health staff result in vaccination.

<sup>e</sup> Iteratively adjusted to match incidence rate of 400–450 per 100,000 per year.

<sup>f</sup> True rate assumed to be the upper range of those reported for this value only.

the unavailability of treatment during this second run-in, but was partially offset by a fitness cost of 30%. That is, transmissibility of MDR-TB was reduced to 70% of that of drug-susceptible strains throughout all analyses ( $\beta_m = 0.7 \times \beta$ ), consistent with the equivocal epidemiological evidence as to whether a significant fitness cost occurs with the development of drug-resistance (Cohen et al., 2003). With these parameters in place, the proportional incidence of MDR-TB (i.e. the flows into compartment  $I_m$  divided by the flows into compartments  $I$  and  $I_m$ ) steadily increased to the target value of 4–6%, such that the model had not reached equilibrium at the start of sensitivity analysis. This simulates the gradual emergence of drug-resistant strains over the period of time that antituberculous antibiotics have been available but treatment for MDR-TB has not. This dynamic condition of the model at the commencement of interventions is most consistent with the likely demographic situation and historical epidemiology.

### 3. Results

#### 3.1. Latency

The cumulative risk of active disease for an individual newly infected with TB under our model, and the common alternative approaches to modelling latency are illustrated in Fig. 2(A). Our use of two latent compartments achieves a close approximation to observed epidemiological data, which is poorly approximated by a single exponential function.

Recently, the risk profile of active infection following exposure has been more clearly delineated in the Netherlands, using molecular techniques in combination with confirmed epidemiological contact (Borgdorff et al., 2011). Our modelled hazard (Fig. 2(B))

closely reflects the observations of this study, with a long period of gradually declining hazard following an initial period of rapidly waning risk. Moreover, in both our modelled approach and this study's results, around half of the twelve year risk accrues over the first 1.5 years following infection.

Other studies have suggested a longer period of initial increased risk, but are less directly applicable to recently infected individuals. For example, new immigrants to Australia, who are likely to vary somewhat in their time from initial infection, are at highest risk for around five to seven years after arrival (MacIntyre et al., 1993; McBryde and Denholm, 2012). Similarly, unvaccinated control children, without known TB exposure and enrolled into a study of BCG vaccination, were at highest risk of developing disease for around the first five to seven years after observation. (Medical Research Council, 1972) Despite the longer period of early risk observed in such studies, the distribution of hazard in these studies would also be poorly modelled by a single exponential function.

#### 3.2. MDR-TB fitness cost

It has previously been argued that MDR-TB is likely to remain a localised problem due to the fitness cost incurred by the organism in developing drug-resistance (Dye et al., 2002). We adjusted the relative fitness of MDR-TB by varying the effective contact rate for MDR-TB ( $\beta_m$ ) relative to that of drug-susceptible TB, without employing the run-in periods described in 2.11. With parameters again set to run-in values, a closed population and no MDR-TB patients commencing treatment for active disease ( $\delta_m = 0$ ), but full availability of treatment for drug-susceptible TB ( $\delta = 0.72$ ), the model was run to equilibrium, while varying the relative fitness between zero and one. This was repeated for full MDR-TB treatment

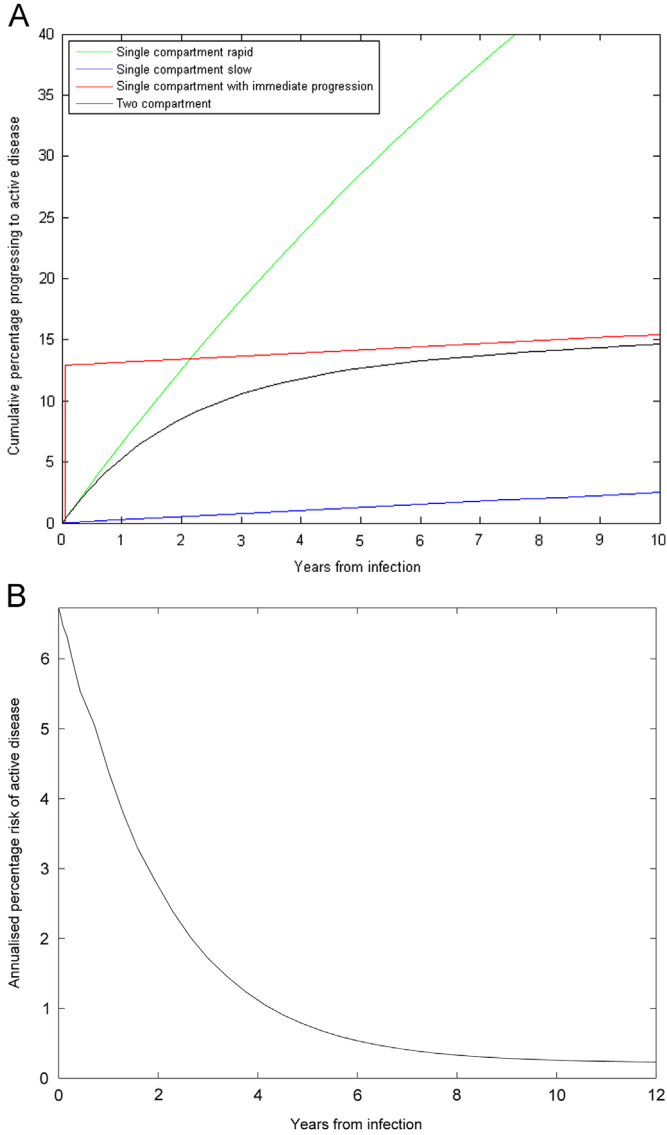

**Fig. 2.** Modelled cumulative risk of active disease and annualised hazard of active disease by time from infection. Part A shows cumulative risk of active disease as modelled using our dual latent compartment approach (black line), compared against model structures using a single latent compartment calibrated to observed early (green line) or late (blue line) risk, and against a model structure using a single latent compartment with proportionate immediate progression (red line). Compare modelled cumulative risk to Fig. 2 of (McBryde and Denholm, 2012). Part B shows annualised percentage risk of active disease over time since infection using our dual latent compartment approach. Compare hazard curve to Fig. 1 of (Borgdorff et al., 2011) (For interpretation of the references to colour in this figure legend, the reader is referred to the web version of this article).

availability ( $\delta_m = \delta$ ) and for partial treatment availability ( $\delta_m = \delta/2$ ) (Fig. 4). The results demonstrate that under our model, if treatment for MDR-TB is either unavailable or partially available, this strain will dominate over time unless a major fitness cost (of at least 40%) is assumed. Even in the case of full treatment availability for MDR-TB (equivalent to drug-susceptible TB) a significant fitness cost (at least 15%) is still required before drug-susceptible TB dominates at equilibrium.

### 3.3. $R_0$

The first step in estimating  $R_0$  was to determine the expected time spent in the infectious compartment ( $T_I$ ) following the introduction of a single individual into the early latent compartment,  $L_A$

(or  $L_{Am}$ ). The state space considered here is  $L_A, L_B, I$ , (or  $L_{Am}, L_{Bm}, I_m$ ) with an initial state space probability of  $[1 \ 0 \ 0 \ 0]$ , reflecting the individual's recent arrival into compartment  $L_A$  (or  $L_{Am}$ ). A transitional probability matrix,  $\mathbf{A}$ , was constructed, in which the  $ij$ th element of  $\mathbf{A}$  was the probability of a single individual from compartment  $i$  transitioning to compartment  $j$  over the short time period  $\Delta t$ , and is given by:

$$\mathbf{A} = \begin{bmatrix} 1 - (\epsilon + \kappa + \mu)\Delta t & \kappa \Delta t & \epsilon \Delta t & \mu \Delta t \\ 0 & 1 - (\nu + \mu)\Delta t & \nu \Delta t & \mu \Delta t \\ 0 & \gamma \Delta t & 1 - (\gamma + \mu_i)\Delta t & \mu_i \Delta t \\ 0 & 0 & 0 & 1 \end{bmatrix}$$

Let  $\mathbf{V}_N = [1 \ 0 \ 0 \ 0] \times \mathbf{A}^N$ .  $\mathbf{V}_N$  is a vector returning the probability of being in the corresponding compartment at the  $N$ th time period, assuming a starting point in the  $L_A$  compartment. Hence,  $\mathbf{V}_N$  (3) is the probability of being in the infectious compartment at this time. Summing over probabilities until  $M$ , when this third element of  $\mathbf{V}_N$  (the probability of being in the infectious compartment) is negligible and multiplying by  $\Delta t$  gives the expected time spent in  $I$  (or similarly,  $I_m$ ). That is,

$$T_I = \Delta t \sum_{N=0}^M [1 \ 0 \ 0 \ 0] \times \mathbf{A}^N \times \begin{bmatrix} 0 \\ 0 \\ 1 \\ 0 \end{bmatrix}$$

which yields a result of 0.99 years spent with active disease following a single infection.

$R_0$  for drug-susceptible TB and  $R_{0m}$  for MDR-TB are then calculated as

$$R_0 = T_I \times \beta^* \times \rho$$

$$R_{0m} = T_I \times \beta_m \times \rho$$

Assuming a fully susceptible population, fully contained within the  $S_A$  compartment of the model at baseline, the values of  $R_0$  and  $R_{0m}$  are 8.34 and 5.84.

\*N.B.  $\beta$  and  $\beta_m$  are the effective contact rate, not the per capita effective contact rate.

### 3.4. Reinfection

As infectiousness of TB is highly dependent on local factors such as contact frequency and overcrowding, we calibrated our model by iteratively adjusting the effective contact rate to match the observed incidence, consistent with previous research (Dowdy et al., 2013). Using the model structure described above, the estimated incidence was achieved using an effective contact rate ( $\beta$ ) of 24 per year.

We hypothesised that if reinfection during latency was removed from the model (i.e. removal of four pathways progressing from  $L_B$  and  $L_{Bm}$  to  $L_A$  and  $L_{Am}$ , but still permitting reinfection after treatment from  $S_B$ ), that a higher effective contact rate would be required to reproduce observed incidence. For this analysis, the model was run to equilibrium with parameters remaining fixed at run-in values, with a closed population and with the fitness cost of MDR-TB adjusted to allow coexistence of the two strains. Fig. 3 shows the relationship between  $\beta$  and incidence rate in the presence and absence of reinfection during latency. Although any reasonable incidence rate can be approximated by adjusting  $\beta$  using the base model structure, if reinfection during latency is removed from the model, it is impossible to produce incidence rates greater than 400 per 100,000 per year and incidence rates above 350 require an implausibly high effective contact rate.

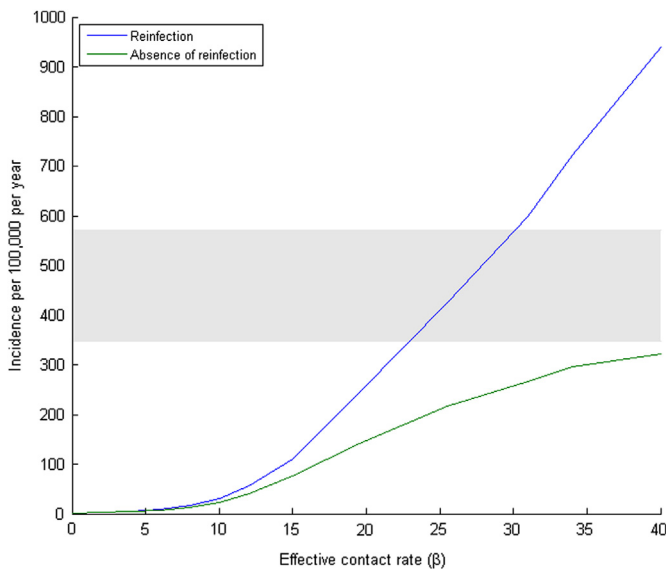

**Fig. 3.** Relationship between effective contact rate ( $\beta$ ) and total TB incidence (drug-susceptible and MDR-TB) in the presence and absence of reinfection. Blue line, base model structure with reinfection permitted; green line, reinfection pathways during latency removed from the model; shaded area, incidence rates in highly endemic countries of the Asia-Pacific (348 to 572 per 100,000 per year) (For interpretation of the references to colour in this figure legend, the reader is referred to the web version of this article).

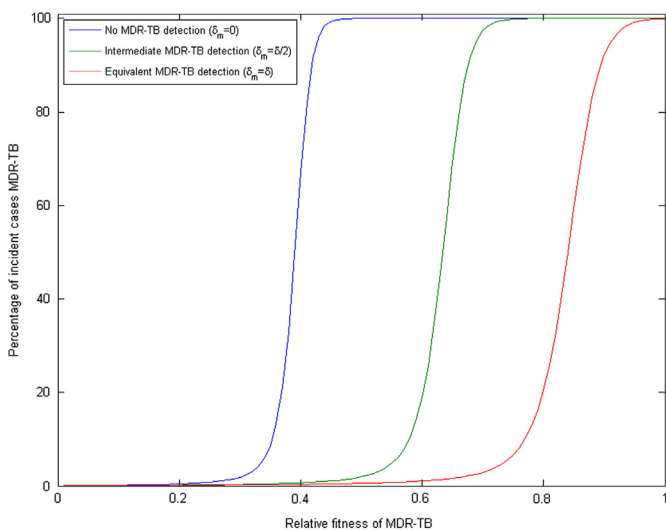

**Fig. 4.** Relationship between relative fitness assigned to MDR-TB and proportion of incident cases MDR-TB at model equilibrium. Blue line, absence of treatment availability for MDR-TB ( $\delta_m=0$ ); green line, partial treatment availability ( $\delta_m=\delta/2$ ); red line, full treatment availability ( $\delta_m=\delta$ ) (For interpretation of the references to colour in this figure legend, the reader is referred to the web version of this article).

### 3.5. Sensitivity analysis

In order to prepare for assessing various programmatic responses to TB control in highly endemic regions of the Asia-Pacific, we performed a sensitivity analysis with preceding run-in periods as described in Section 2.10.

As population growth is known to significantly impact TB dynamics (Aparicio and Castillo-Chavez, 2009; Aparicio et al., 2002), after both run-ins were completed, population growth was introduced throughout the sensitivity analysis period to best reflect the current dynamic demographic situation observed in the target countries. Sensitivity analysis was then performed by varying the modifiable programmatic parameters (BCG vaccination rate [ $\iota$ ], treatment of drug-

susceptible TB [ $\delta$ ], treatment of MDR-TB [ $\delta_m$ ] and default [ $\omega$ ]) with Latin Hypercube sampling. Results are presented as the effect of varying these parameter values on the outcomes of population-wide drug-susceptible incidence, MDR-TB incidence and mortality after the model has run for ten years.

Fig. 5 shows that the incidence of drug-susceptible TB is highly sensitive to the rate of detection, but is relatively insensitive to rates of vaccination and treatment default. Incidence of MDR-TB is also insensitive to rates of vaccination, but sensitive to the rate of detection and more sensitive to the rate of default than the drug-susceptible strain, due to the longer treatment duration. MDR-TB incidence tends to increase with improved detection and treatment of drug-susceptible disease. Total TB-specific mortality is sensitive to rates of detection and treatment of both strains of TB.

### 3.6. Importance of *de novo* resistance mutation versus transmission of MDR-TB

Under our model structure, the number of new incident cases of MDR-TB that occur as the result of *de novo* resistance mutation exceeds the number due to transmission of MDR-TB when:

$$\eta\omega T > \varepsilon L_{Am} + \nu L_{Bm}$$

At the commencement of the second run-in period, the proportion of the population in the compartments representing infection with MDR-TB ( $L_{Am}$ ,  $L_{Bm}$ ,  $I_m$  and  $T_m$ ) is zero, while most of the population (65%) is contained within the drug-susceptible TB latent compartments ( $L_A$ ,  $L_B$ ). Initially, when *de novo* acquisition of resistance is introduced, this constitutes the dominant pathway for incident MDR-TB cases. However, this process is rapidly overtaken by community transmission of MDR-TB, as the proportion of the population infected with MDR-TB increases. The acquisition pathway dominates for the first four years following introduction of MDR-TB, until MDR-TB reaches 0.5% of all incident TB cases, after which transmission dominates. At the completion of the run-in periods, with MDR-TB contributing 5.1% of all incident cases, *de novo* resistance is responsible for 8.5% of all incident cases of MDR-TB, with the remainder resulting from community transmission.

## 4. Discussion and conclusion

We aimed to extend previous tuberculosis transmission models to build a model applicable to areas of our region hyperendemic for TB, but with lower HIV prevalence than other high burden regions. There are several elaborations in our model that incorporate or extend recent advances in this field, namely; BCG conferring partial protection against first infection with TB, including two latent compartments to represent progression to active disease after infection, allowing for reinfection during latency and after treatment, concurrent circulation of two strains differing by drug-susceptibility, mortality and infectivity modification with treatment, and amplification of resistance occurring at a rate proportional to default from treatment of drug-susceptible disease. While previous models have considered some of these aspects of model construction, we argue that integrating all these components best reflects current understanding of TB transmission. Other investigators have considered response to TB control in highly endemic countries of our region (Hickson et al., 2012), but were constructed primarily to assess cross-border risk of transmission. We present this base model with the intention of subsequently using it to simulate multi-component programmatic responses to TB control in the Asia-Pacific.

Our model does not incorporate separate compartments for infectious and non-infectious active tuberculosis patients, as some previous models have done, primarily to represent

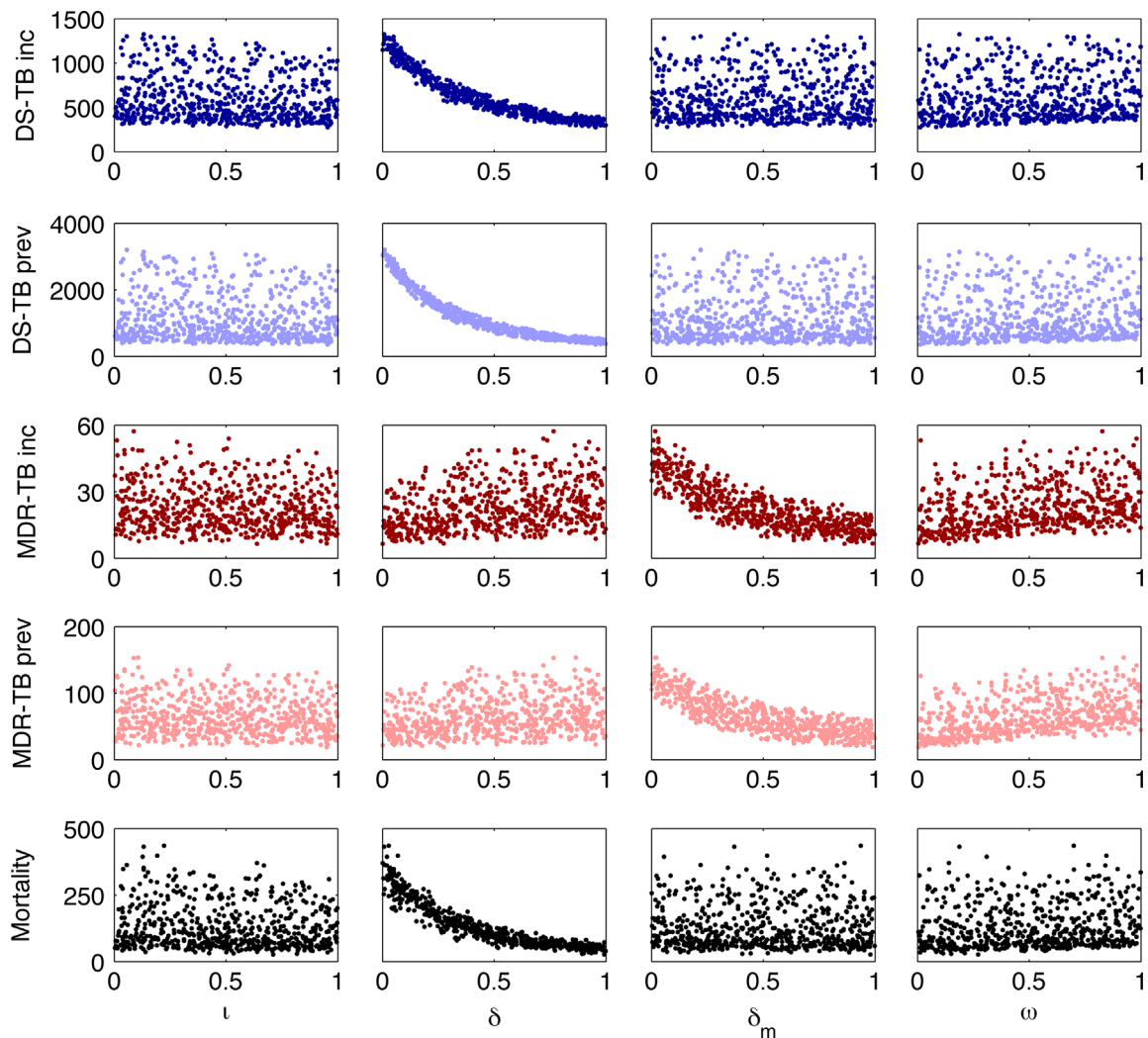

**Fig. 5.** Sensitivity analysis of variable programmatic parameters on epidemiological outcomes. BCG vaccination rate ( $\tau$ ), treatment of drug-susceptible TB ( $\delta$ ), treatment of MDR-TB ( $\delta_m$ ) and default ( $\omega$ ) are varied between zero and one using Latin Hypercube sampling to determine the effect on drug-susceptible incidence (per 100,000 per year), drug-susceptible prevalence (per 100,000), MDR-TB incidence (per 100,000 per year), MDR-TB prevalence (per 100,000) and total TB-specific mortality (per 100,000 per year). DS-TB inc, drug-susceptible tuberculosis incidence; DS-TB prev, drug-susceptible tuberculosis prevalence; MDR-TB inc, multidrug resistant tuberculosis incidence; MDR-TB prev, multidrug resistant tuberculosis prevalence.

the markedly different degrees of infectivity for such patients (Abu-Raddad et al., 2009; Blower et al., 1995; Dye and Williams, 2008). However, we incorporate the decreased infectivity of smear-negative and extrapulmonary tuberculosis patients by multiplying the force of infection by the proportion of the active infection compartment smear-positive. This is a valid approach provided that such patients have comparable rates of death, spontaneous recovery and detection as the infectious cases. However, duplication of the infectious ( $I$  and  $I_m$ ) compartments should be considered if programmatic interventions are considered that would be expected to detect patients with smear-positive disease at a substantially different rate from non-smear-positive patients.

Under its current structure, our model does not directly incorporate age effects, although age is known to affect tuberculosis progression and transmission. To fully consider these effects using a compartmental model, a detailed age structure with stratification at multiple levels is necessary (Aparicio and Castillo-Chavez, 2009). However, without such stratification, our model does implicitly consider two such age effects under its current structure. First, the likely brief period of increased susceptibility of unvaccinated children to TB in a hyperendemic setting is simulated by births occurring into the unvaccinated compartment ( $S_A$ ), but with little of the population remaining in

this compartment over time. Second, the lower contribution of children to the overall force of infection is incorporated in the  $\rho$  parameter, the denominator of which includes all smear-negative and extrapulmonary cases and so would include most paediatric cases. Rates of progression to active disease following infection and disease-specific mortality are parameterised with epidemiological estimates of population mean values, although younger age is likely to be associated with a shorter duration of latency and increased disease severity. However, the effect on latency is likely to decline for several decades after birth, and age is not the only demographic factor likely to modify this effect. Moreover, many of these effects are also likely to be modified by comorbidities (such as diabetes and HIV), pulmonary versus extrapulmonary status, local disease dynamics, etc. (Borgdorff et al., 2011). Future work will use microsimulation modelling to better incorporate these factors.

The known increase in disease risk in the years immediately following infection appears well represented by the inclusion of two sequential latent compartments, with the profile of risk over time initially waning rapidly, but with a small but significant hazard persisting for many years to decades. The parameterisation of this aspect of the model results in a greater proportion of risk accruing early after infection than that seen in new immigrants to



Australia, although this group includes both recently infected and distantly infected individuals. However, the risk profile compares favourably to molecular epidemiological data describing the incubation period for known source-secondary couples, which is also intended as the subject of future research.

Whether drug-resistant forms of TB, such as MDR-TB, have a fitness cost relative to susceptible strains is often debated (Zumla et al., 2012), and this potential fitness cost has previously been used to argue that fully addressing MDR-TB may not be necessary to achieve control (Dye et al., 2002). However, when our model is run to equilibrium in the absence of treatment availability for MDR-TB, the drug-resistant strain dominates unless a major transmissibility cost of greater than 40% is assumed. This occurs due to differences in programmatic responses, despite  $R_0$  being equal for both strains under our model until the fitness cost modification is applied. Moreover, even in the presence of partial or complete treatment availability for MDR-TB, drug-resistance dominates unless significant transmissibility costs are incorporated.

Previous models incorporating cluster effects have considered the importance of reinfection during latency to TB dynamics (Aparicio et al., 2000; Cohen et al., 2007), and recent models increasingly utilise such pathways. We demonstrate that if this process is not included, it is impossible to simulate the incidence rates observed in our region's most highly endemic areas. In countries affected by dual epidemics of both HIV and TB, incidence rates of over 400 may be partly explained by increased rates of progression to active disease following exposure ( $\epsilon$  and  $\nu$  in our model). However, in the absence of widespread immunocompromise, the parameters we employed should remain valid, with greater intensity of exposure likely to explain the high disease incidence. Despite this, in the absence of reinfection during latency, incidence rates above 400 per 100,000 per year cannot be effectively simulated by adjusting the effective contact rate under our model structure. A recent report from Papua New Guinea describes an extremely high incidence rate (1290 per 100,000 per year) in the presence of only 1.9% HIV coinfection (Cross et al., 2014). Therefore, we believe that reinfection during latency is a key driver of the TB epidemic in such high burden, low HIV prevalence regions.

Sensitivity analysis of parameters representing programmatic responses to TB control demonstrated that rates of detection and commencement on treatment were the most important parameters in determining subsequent disease incidence for each strain, and were both also important predictors of population-wide mortality. Vaccination rate had little impact, partly due to little of the population (< 10%)

remaining within the unvaccinated, fully susceptible compartment. Rather than preventing the emergence of MDR-TB through amplification, improved treatment of drug-susceptible disease resulted in a slight increase in MDR-TB rates. As most new cases of MDR-TB occurred due to community transmission of resistant strains and the majority of the population were latently infected with drug-susceptible TB at the end of the run-in periods, this occurred through the gradual replacement of drug-susceptible TB by MDR-TB within the pool of latently infected individuals. That is, effective treatment of drug-susceptible disease could paradoxically lead to increased incidence of MDR-TB in a highly endemic setting through strain replacement. Progression from latent to active infection was responsible for a considerably greater proportion of new cases than amplification of resistance in previously drug-susceptible strains once the proportion of circulating MDR-TB strains passed 1%. As expected, increasing default rates had a greater impact on MDR-TB than drug-susceptible TB, as default rates were kept constant over time and the treatment period for MDR-TB is considerably longer, although these effects were modest. Therefore, our model suggests that concern over emergence of resistance with high default rates should not be taken as an argument against increasing case detection and treatment.

The model we present incorporates recent advances in model construction and current understanding of TB epidemiology. It also behaves in a plausible manner in response to variation of parameters representing programmatic responses to TB control. Its behaviour highlights the importance of reinfection during latency in a highly endemic region, as well as demonstrating that MDR-TB is likely to remain important even if a moderate fitness cost is assumed.

## Acknowledgements

James Trauer is a National Health and Medical Research Postgraduate Scholarship recipient for doctoral studies in tuberculosis. Emma McBryde is a National Health and Medical Research Council Career Development Fellowship recipient. We acknowledge the support of the Australian Government.

## Appendix A

See the Appendix [Table A2](#).

**Table A2**

Country	Total incidence	Proportion notified cases MDR-TB	Attended births	HIV prevalence in ages 15–49	Case detection rate	Treatment success <sup>a</sup>	Proportion smear-positive <sup>b</sup>	Crude birth rate	Life expectancy
Unit	per 100,000 per year	%	%	%	%	%	%	per 1000	Years
SEARO countries									
DR Korea	409	4.1	100	–	91	90	38	15	69
Myanmar	403	4.2	70.6	0.6	71	86	32	18	65
Timor-Leste	498	2.1	29.3	–	69	91	41	37	64
WPRO countries									
Cambodia	411	1.0	73.5	0.6	66	94	40	26	65
Kiribati	429	4.3	79.8	–	80	95	41	24	67
Marshall Islands	572	3	99	–	48	88	40	–	60
Papua New Guinea	348	5.3	53	0.7	82	69	14	31	63

<sup>a</sup> Sum of percentage of outcomes resulting in either completion or cure.

<sup>b</sup> Calculated as: [total notifications – extrapulmonary cases] ÷ [total notifications] (i.e. proportion of new cases pulmonary) × [proportion smear-positive among new pulmonary cases]. References for table: [United Nations Department of Economic and Social Affairs/Population Division \(2012\)](#), [World Health Organisation \(2013a, 2013b, 2013c\)](#).

## References

- Abu-Raddad, L.J., Sabatelli, L., Achterberg, J.T., Sugimoto, J.D., Longini Jr., I.M., Dye, C., Halloran, M.E., 2009. Epidemiological benefits of more-effective tuberculosis vaccines, drugs, and diagnostics. *Proc. Natl. Acad. Sci. USA* 106 (33), 13980–13985.
- Aparicio, J.P., Castillo-Chavez, C., 2009. Mathematical modelling of tuberculosis epidemics. *Math. Biosci. Eng.* 6 (2), 209–237.
- Aparicio, J.P., Capurro, A.F., Castillo-Chavez, C., 2000. Transmission and dynamics of tuberculosis on generalized households. *J. Theor. Biol.* 206 (3), 327–341.
- Aparicio, J.P., Capurro, A.F., Castillo-Chavez, C., 2002. Markers of disease evolution: the case of tuberculosis. *J. Theor. Biol.* 215 (2), 227–237.
- Bandera, A., Gori, A., Catozzi, L., Degli Esposti, A., Marchetti, G., Molteni, C., Ferrario, G., Codecasa, L., Penati, V., Matteelli, A., Franzetti, F., 2001. Molecular epidemiology study of exogenous reinfection in an area with a low incidence of tuberculosis. *J. Clin. Microbiol.* 39 (6), 2213–2218.
- Basu, S., Galvani, A.P., 2008. The transmission and control of XDR TB in South Africa: an operations research and mathematical modelling approach. *Epidemiol. Infect.* 136 (12), 1585–1598.
- Blower, S.M., Chou, T., 2004. Modeling the emergence of the 'hot zones': tuberculosis and the amplification dynamics of drug resistance. *Nat. Med.* 10 (10), 1111–1116.
- Blower, S.M., Small, P.M., Hopewell, P.C., 1996. Control strategies for tuberculosis epidemics: new models for old problems. *Science* 273 (5274), 497–500.
- Blower, S.M., McLean, A.R., Porco, T.C., Small, P.M., Hopewell, P.C., Sanchez, M.A., Moss, A.R., 1995. The intrinsic transmission dynamics of tuberculosis epidemics. *Nat. Med.* 1 (8), 815–821.
- Borgdorff, M.W., Sebek, M., Geskus, R.B., Kremer, K., Kalisvaart, N., van Soolingen, D., 2011. The incubation period distribution of tuberculosis estimated with a molecular epidemiological approach. *Int. J. Epidemiol.* 40 (4), 964–970.
- Castillo-Chavez, C., Feng, Z., 1997. To treat or not to treat: the case of tuberculosis. *J. Math. Biol.* 35 (6), 629–656.
- Castillo-Chavez, C., Song, B., 2004. Dynamic models of tuberculosis and their applications. *Math. Biosci. Eng.* 1 (2), 361–404.
- Cohen, T., Sommers, B., Murray, M., 2003. The effect of drug resistance on the fitness of *Mycobacterium tuberculosis*. *Lancet Infect. Dis.* 3 (1), 13–21.
- Cohen, T., Colijn, C., Finklea, B., Murray, M., 2007. Exogenous re-infection and the dynamics of tuberculosis epidemics: local effects in a network model of transmission. *J. R. Soc. Interface* 4 (14), 523–531.
- Cohen, T., Dye, C., Colijn, C., Williams, B., Murray, M., 2009. Mathematical models of the epidemiology and control of drug-resistant TB. *Expert. Rev. Respir. Med.* 3 (1), 67–79.
- Colditz, G.A., Brewer, T.F., Berkey, C.S., Wilson, M.E., Burdick, E., Fineberg, H.V., Mosteller, F., 1994. Efficacy of BCG vaccine in the prevention of tuberculosis. Meta-analysis of the published literature. *JAMA* 271 (9), 698–702.
- Colijn, C., Cohen, T., Murray, M., 2009. Latent coinfection and the maintenance of strain diversity. *Bull. Math. Biol.* 71 (1), 247–263.
- Cox, H.S., Niemann, S., Ismailov, G., Doshetov, D., Orozco, J.D., Blok, L., Rusch-Gerdes, S., Kebede, Y., 2007. Risk of acquired drug resistance during short-course directly observed treatment of tuberculosis in an area with high levels of drug resistance. *Clin. Infect. Dis.* 44 (11), 1421–1427.
- Cross, G.B., Coles, K., Nikpour, M., Moore, O.A., Denholm, J., McBryde, E.S., Eisen, D. P., Warigi, B., Carter, R., Pandey, S., Harino, P., Siba, P., Coulter, C., Mueller, I., Phuanukoonnon, S., Pellegrini, M., 2014. TB incidence and characteristics in the remote gulf province of Papua New Guinea: a prospective study. *BMC Infect. Dis.* 14 (1), 93.
- Das, S., Paramasivan, C.N., Lowrie, D.B., Prabhakar, R., Narayanan, P.R., 1995. IS6110 restriction fragment length polymorphism typing of clinical isolates of *Mycobacterium tuberculosis* from patients with pulmonary tuberculosis in Madras, south India. *Tuber Lung Dis.* 76 (6), 550–554.
- Diel, R., Lodenkemper, R., Niemann, S., Meywald-Walter, K., Nienhaus, A., 2011. Negative and positive predictive value of a whole-blood interferon-gamma release assay for developing active tuberculosis: an update. *Am. J. Respir. Crit. Care Med.* 183 (1), 88–95.
- Dowdy, D.W., Dye, C., Cohen, T., 2013. Data needs for evidence-based decisions: a tuberculosis modeler's 'wish list'. *Int. J. Tuberc. Lung Dis.* 17 (7), 866–877.
- Dowdy, D.W., Chaisson, R.E., Maartens, G., Corbett, E.L., Dorman, S.E., 2008. Impact of enhanced tuberculosis diagnosis in South Africa: a mathematical model of expanded culture and drug susceptibility testing. *Proc. Natl. Acad. Sci. USA* 105 (32), 11293–11298.
- Dye, C., 2012. The potential impact of new diagnostic tests on tuberculosis epidemics. *Indian J. Med. Res.* 135 (5), 737–744.
- Dye, C., Williams, B.G., 2008. Eliminating human tuberculosis in the twenty-first century. *J. R. Soc. Interface* 5 (23), 653–662.
- Dye, C., Garnett, G.P., Sleeman, K., Williams, B.G., 1998. Prospects for worldwide tuberculosis control under the WHO DOTs strategy. *Lancet* 352 (9144), 1886–1891.
- Dye, C., Williams, B.G., Espinal, M.A., Ravigione, M.C., 2002. Erasing the world's slow stain: strategies to beat multidrug-resistant tuberculosis. *Science* 295 (5562), 2042–2046.
- Feng, Z., Castillo-Chavez, C., Capurro, A.F., 2000. A model for tuberculosis with exogenous reinfection. *Theor. Popul. Biol.* 57 (3), 235–247.
- Feng, Z., Huang, W., Castillo-Chavez, C., 2001. On the role of variable latent periods in mathematical models of tuberculosis. *J. Dyn. Differ. Equ.* 13 (2), 28.
- Feng, Z., Iannelli, M., Milner, F.A., 2002. A two-strain tuberculosis model with age of infection. *SIAM J. Appl. Math.* 62 (5), 1634–1656.
- Fitzwater, S.P., Caviedes, L., Gilman, R.H., Coronel, J., LaChira, D., Salazar, C., Saravia, J.C., Reddy, K., Friedland, J.S., Moore, D.A., 2010. Prolonged infectiousness of tuberculosis patients in a directly observed therapy short-course program with standardized therapy. *Clin. Infect. Dis.* 51 (4), 371–378.
- Gilpin, C.M., Simpson, G., Vincent, S., O'Brien, T.P., Knight, T.A., Globan, M., Coulter, C., Konstantinos, A., 2008. Evidence of primary transmission of multidrug-resistant tuberculosis in the Western Province of Papua New Guinea. *Med. J. Aust.* 188 (3), 148–152.
- Gomes, M.G., Aguas, R., Lopes, J.S., Nunes, M.C., Rebelo, C., Rodrigues, P., Struchiner, C.J., 2012. How host heterogeneity governs tuberculosis reinfection? *Proc. Biol. Sci.* 279 (1737), 2473–2478.
- Harries, A.D., Hargreaves, N.J., Gausi, F., Kwanjana, J.H., Salaniponi, F.M., 2001. High early death rate in tuberculosis patients in Malawi. *Int. J. Tuberc. Lung Dis.* 5 (11), 1000–1005.
- Hickson, R.I., Mercer, G.N., Lokuge, K.M., 2012. A metapopulation model of tuberculosis transmission with a case study from high to low burden areas. *PLoS One* 7 (4), e34411.
- Lambert, M.L., Hasker, E., Van Deun, A., Roberfroid, D., Boelaert, M., Van der Stuyft, P., 2003. Recurrence in tuberculosis: relapse or reinfection? *Lancet Infect. Dis.* 3 (5), 282–287.
- MacIntyre, C.R., Dwyer, B., Streeeton, J.A., 1993. The epidemiology of tuberculosis in Victoria. *Med. J. Aust.* 159 (10), 672–677.
- McBryde, E.S., Denholm, J.T., 2012. Risk of active tuberculosis in immigrants: effects of age, region of origin and time since arrival in a low-exposure setting. *Med. J. Aust.* 197 (8), 458–461.
- Medical Research Council, 1972. BCG and vole bacillus vaccines in the prevention of tuberculosis in adolescence and early adult life. *Bull. World Health Organ.* 46 (3), 371–385.
- Moolphate, S., Aung, M.N., Nampaisan, O., Nedsuwan, S., Kantipong, P., Suriyon, N., Hansudewechakul, C., Yanai, H., Yamada, N., Ishikawa, N., 2011. Time of highest tuberculosis death risk and associated factors: an observation of 12 years in Northern Thailand. *Int. J. Gen. Med.* 4, 181–190.
- Raleigh, J.W., Wichelhausen, R., 1973. Exogenous reinfection with *Mycobacterium tuberculosis* confirmed by phage typing. *Am. Rev. Respir. Dis.* 108 (3), 639–642.
- ReVelle, C.S., Lynn, W.R., Feldmann, F., 1967. Mathematical models for the economic allocation of tuberculosis control activities in developing nations. *Am. Rev. Respir. Dis.* 96 (5), 893–909.
- Rodrigues, P., Gomes, M.G., Rebelo, C., 2007. Drug resistance in tuberculosis—a reinfection model. *Theor. Popul. Biol.* 71 (2), 196–212.
- Sahadevan, R., Narayanan, S., Paramasivan, C.N., Prabhakar, R., Narayanan, P.R., 1995. Restriction fragment length polymorphism typing of clinical isolates of *Mycobacterium tuberculosis* from patients with pulmonary tuberculosis in Madras, India, by use of direct-repeat probe. *J. Clin. Microbiol.* 33 (11), 3037–3039.
- Sergeev, R., Colijn, C., Cohen, T., 2011. Models to understand the population-level impact of mixed strain *Mycobacterium tuberculosis* infections. *J. Theor. Biol.* 280 (1), 88–100.
- Sergeev, R., Colijn, C., Murray, M., Cohen, T., 2012. Modeling the dynamic relationship between HIV and the risk of drug-resistant tuberculosis. *Sci. Transl. Med.* 4 (135)135ra167.
- Sonnenberg, P., Murray, J., Glynn, J.R., Shearer, S., Kambashi, B., Godfrey-Faussett, P., 2001. HIV-1 and recurrence, relapse, and reinfection of tuberculosis after cure: a cohort study in South African mineworkers. *Lancet* 358 (9294), 1687–1693.
- Sutherland, I., Svandova, E., Radhakrishna, S., 1982. The development of clinical tuberculosis following infection with tubercle bacilli. I. A theoretical model for the development of clinical tuberculosis following infection, linking from data on the risk of tuberculosis infection and the incidence of clinical tuberculosis in the Netherlands. *Tubercle* 63 (4), 255–268.
- Tiemersma, E.W., van der Werf, M.J., Borgdorff, M.W., Williams, B.G., Nagelkerke, N.J., 2011. Natural history of tuberculosis: duration and fatality of untreated pulmonary tuberculosis in HIV negative patients: a systematic review. *PLoS ONE [Electronic Resource]* 6 (4), e17601.
- United Nations Department of Economic and Social Affairs/Population Division, 2012. *World Population Prospects: The 2012 Revision*, vol. 2, pp. 1–4.
- van der Werf, M.J., Langendam, M.W., Huitric, E., Manissero, D., 2012. Multidrug resistance after inappropriate tuberculosis treatment: a meta-analysis. *Eur. Respir. J.* 39 (6), 1511–1519.
- van Rie, A., Warren, R., Richardson, M., Victor, T.C., Gie, R.P., Enarson, D.A., Beyers, N., van Helden, P.D., 1999. Exogenous reinfection as a cause of recurrent tuberculosis after curative treatment. *N. Engl. J. Med.* 341 (16), 1174–1179.
- Verver, S., Warren, R.M., Beyers, N., Richardson, M., van der Spuy, G.D., Borgdorff, M. W., Enarson, D.A., Behr, M.A., van Helden, P.D., 2005. Rate of reinfection tuberculosis after successful treatment is higher than rate of new tuberculosis. *Am. J. Respir. Crit. Care Med.* 171 (12), 1430–1435.
- Vynnycky, E., Fine, P.E., 1997. The natural history of tuberculosis: the implications of age-dependent risks of disease and the role of reinfection. *Epidemiol. Infect.* 119 (2), 183–201.
- Waalder, H., Geser, A., Andersen, S., 1962. The use of mathematical models in the study of the epidemiology of tuberculosis. *Am. J. Publ. Health Nations Health* 52, 1002–1013.
- World Bank, 2013. *World Development Indicators*.
- World Health Organisation, 2010. *Treatment of Tuberculosis Guidelines*. WHO, Geneva, Switzerland.
- World Health Organisation, 2013a. *Global Health Observatory Data Repository*, Data on the size of the HIV/AIDS epidemic: Prevalence of HIV among adults aged 15

- to 49 (%) by country. vol. 2013. World Health Organisation, Geneva, Switzerland.
- World Health Organisation, 2013b. Global Health Observatory Data Repository. Life expectancy: Life expectancy by country 2011. vol. 2013. World Health Organisation, Geneva, Switzerland.
- World Health Organisation, 2013c. Global Tuberculosis Report 2013. Vol. 2011. WHO, Geneva, Switzerland.
- Wu, P., Lau, E.H., Cowling, B.J., Leung, C.C., Tam, C.M., Leung, G.M., 2010. The transmission dynamics of tuberculosis in a recently developed Chinese city. *PLoS One* 5 (5), e10468.
- Ziegler, J.E., Edwards, M.L., Smith, D.W., 1985. Exogenous reinfection in experimental airborne tuberculosis. *Tubercle* 66 (2), 121–128.
- Ziv, E., Daley, C.L., Blower, S.M., 2001. Early therapy for latent tuberculosis infection. *Am. J. Epidemiol.* 153 (4), 381–385.
- Zumla, A., Abubakar, I., Raviglione, M., Hoelscher, M., Ditiu, L., McHugh, T.D., Squire, S.B., Cox, H., Ford, N., McNerney, R., Marais, B., Grobusch, M., Lawn, S.D., Migliori, G.B., Mwaba, P., O'Grady, J., Pletschette, M., Ramsay, A., Chakaya, J., Schito, M., Swaminathan, S., Memish, Z., Maeurer, M., Atun, R., 2012. Drug-resistant tuberculosis—current dilemmas, unanswered questions, challenges, and priority needs. *J. Infect. Dis.* 205 (Suppl 2), S228–S240.